

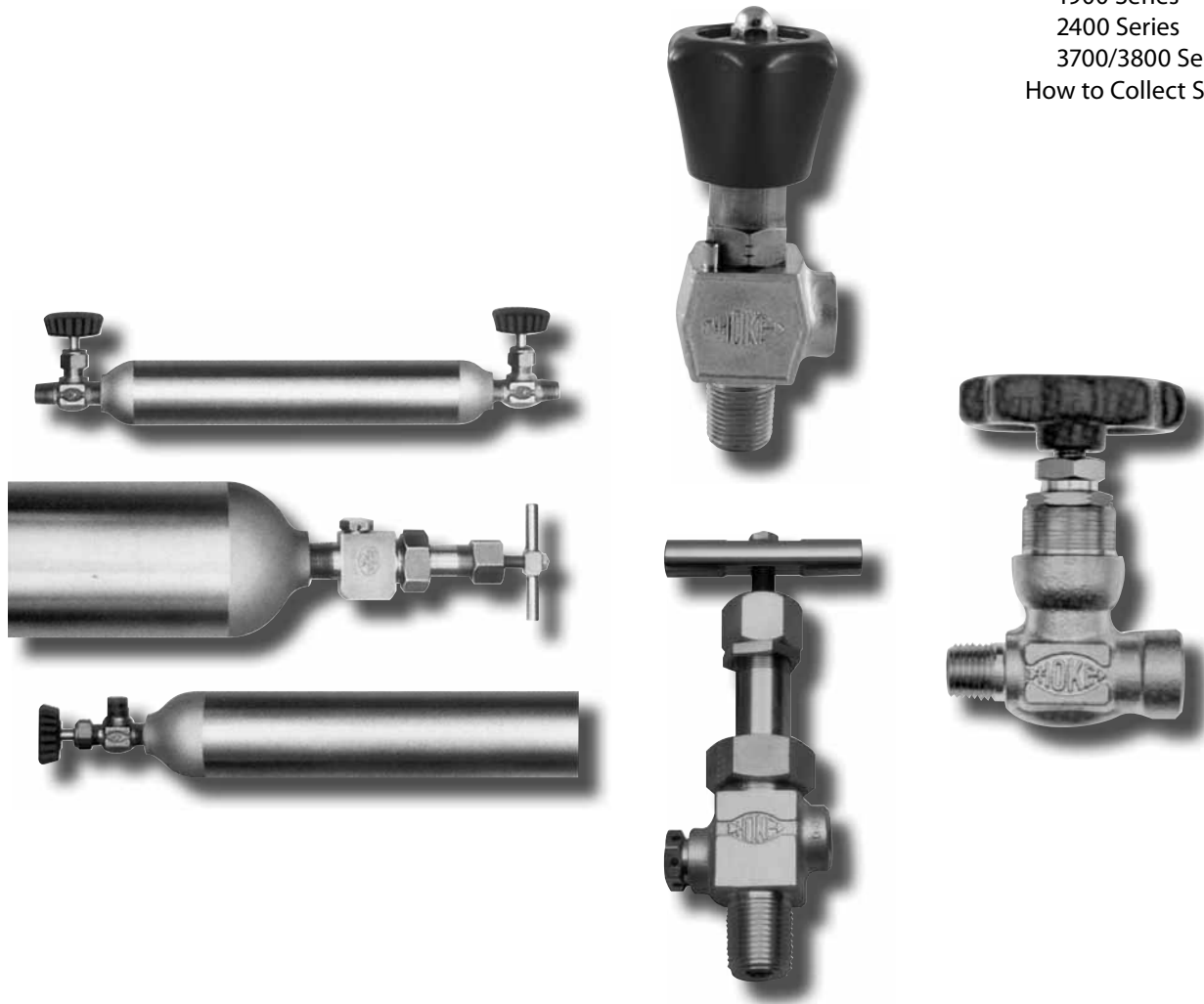

Formed Sampling Cylinders and Accessories

Index

| | |
|--|----|
| Sampling Cylinders | 2 |
| Design, Features, Applications | |
| Cylinder Accessories | 3 |
| Collars, Flanges, Caps, Carrying Handles | |
| Safety Relief Devices | |
| Cylinder Valves | |
| 1700 Series | 5 |
| 1900 Series | 6 |
| 2400 Series | 8 |
| 3700/3800 Series | 10 |
| How to Collect Samples | 12 |



sampling cylinders



Formed Sampling Cylinders & Accessories

Hoke Sampling Cylinders are designed and manufactured to stringent U.S. Department of Transportation (DOT) specifications to provide long performance life and maximum safety to the user.

These cylinders are fabricated from seamless tubing or pipe with increased wall thickness in the threaded area, which prevents expansion when valves are installed. Completely formed ends maximize strength and eliminate potential leak paths. Internal sandblasting removes surface imperfections and removes foreign particles.

Single- and double-ended cylinders are available as standard in a variety of capacities from 10 milliliters to 4 gallons.

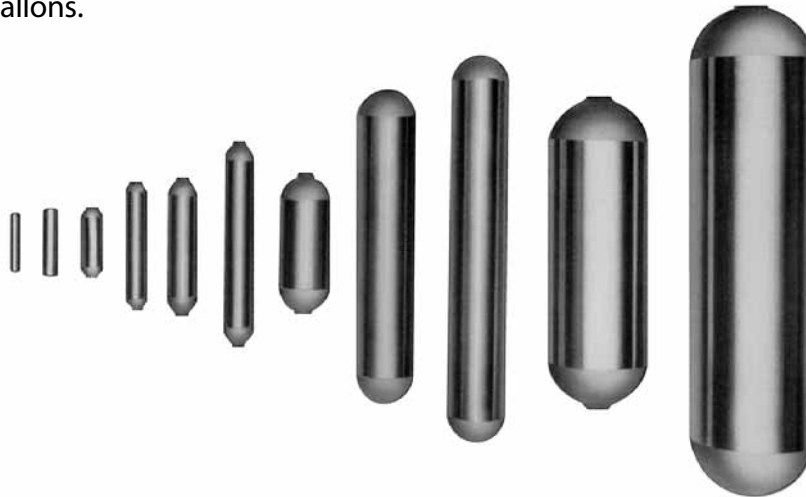

Typical Applications

- Sampling hydrocarbons in refineries and petrochemical plants
- Grab sampling for chromatographic analysis
- Snubbers in reactor feed lines
- Surge accumulators in High Pressure Gas Systems
- High Vacuum Systems as experimental chambers and molecular sieves
- Chemical reaction vessels

Features & Benefits

- Choice of 12 different capacities from 10 mL through 4 gallons.
- Cylinder ends come in 1/8", 1/4", 3/8" and 1/2" NPT female connections (depends on capacity).
- Standard cylinders are formed from seamless drawn 304 SS, 316 SS or Monel® pipe or tubing.
- Precision spinning operation eliminates internal pockets and provides easy flow of the sample.
- All models are internally sandblasted to remove surface imperfections and eliminate foreign particles.
- Single- and double-ended cylinders in most capacities are available as standard.
- Rugged wall thickness – extra strength around threads.
- Cylinders may be ordered with valves, relief devices, dip tubes, carrying handles, collar and flanges and end caps.
- The interior of Hoke cylinders are available with a special FEP lining which provides excellent lubricity and very low permeability. To order, add "TL" following the cylinder part number. Restek®, Silcosteel®, and Sulfinert® surface treatments available for many sizes. Consult factory.
- Special High Tolerance NPT Thread

HOKE Incorporated

405 Centura Court • PO Box 4866 (29305) • Spartanburg, SC 29303
Phone (864) 574-7966 Fax (864) 587-5608
www.hoke.com • sales@hoke.com

formed sampling cylinders

Formed Sampling Cylinders

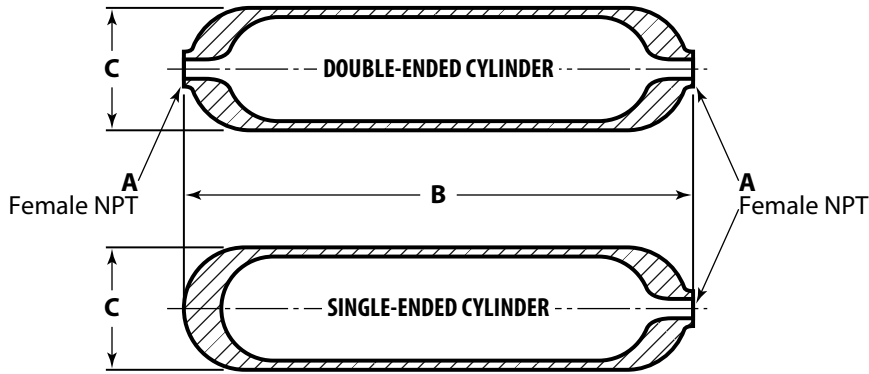

FOR YOUR SAFETY

IT IS SOLELY THE RESPONSIBILITY OF THE SYSTEM DESIGNER AND USER TO SELECT PRODUCTS SUITABLE FOR THEIR SPECIFIC APPLICATION REQUIREMENTS AND TO ENSURE PROPER INSTALLATION, OPERATION AND MAINTENANCE OF THESE PRODUCTS. MATERIAL COMPATIBILITY, PRODUCT RATINGS AND APPLICATION DETAILS SHOULD BE CONSIDERED IN THE SELECTION. IMPROPER SELECTION OR USE OF PRODUCTS DESCRIBED HEREIN CAN CAUSE PERSONAL INJURY OR PROPERTY DAMAGE.

Formed Cylinders: 316 Stainless Steel only

Pressure ratings up to 5000 psig can be supplied as a special. Consult the factory for quotation of any cylinder rated above 1800 psig.

When testing to ASME specifications is required, contact Hoke for quotation and specify maximum pressure and temperature

To learn more about DOT-rated Cylinders, please read Hoke *Spun Sampling Cylinders* catalog, Part #79006.

Other Materials

Cylinders manufactured from other materials are available. Contact Hoke for quotation.

Teflon®-lined Cylinders

The interior of Hoke cylinders are available with a special FEP lining which provides excellent lubricity and very low permeability. To order add "Teflon®-lined" following the cylinder part number.

How to Order

To order a Hoke Sampling Cylinder, specify the model number based on capacity required, single- or double-end connections and end connection size.

Dimensions & How to Order

| PRESSURE RATING psig [bar] | INTERNAL VOLUME | A inch | ORDERING NUMBERS | | DIMENSIONS inch [mm] | | WEIGHT lb (kg) |
|---|-----------------|-----------|------------------|--------------|----------------------|--------------------------------------|-------------------|
| | | | SINGLE ENDED | DOUBLE ENDED | LENGTH B | OUTSIDE DIAMETER C | |
| 304 Stainless Steel, 400 psig [28 bar] | | | | | | | |
| 400 [28] | 1000 mL | ½ | * | 8LD1000 | 10.5 [627] | 3.5 [89] | 4.5 [2.0] |
| | 2250 mL | ½ | * | 8LD2250 | 15.25 [387] | 4.0 [102] | 7.0 [3.0] |
| | 3000 mL | ½ | * | 8LD3000 | 19.5 [489] | 4.0 [104] | 8.4 [3.8] |
| | 1 gal. | ½ | * | 8LD1G | 23.75 [603] | 4.0 [104] | 10.25 [4.6] |
| 304 Stainless Steel, 1800 psig [124 bar] | | | | | | | |
| 1800 [124] | 75 mL | ¼ | 4HS75 | 4HD75 | 5 [127] | 1.5 [38] | 0.75 [0.33] |
| | 75 mL | ⅜ | 6HS75 | 6HD75 | 5 [127] | 1.5 [38] | 0.75 [0.33] |
| | 150 mL | ¼ | 4HS150 | 4HD150 | 9 [229] | 1.5 [38] | 1.38 [0.61] |
| | 150 mL | ⅜ | 6HS150 | 6HD150 | 9 [229] | 1.5 [38] | 1.38 [0.61] |
| | 300 mL | ¼ | 4HS300 | 4HD300 | 9.75 [248] | 2.0 [51] | 2.0 [0.9] |
| | 300 mL | ⅜ | 6HS300 | 6HD300 | 9.75 [248] | 2.0 [51] | 2.0 [0.9] |
| | 500 mL | ¼ | 4HS500 | 4HD500 | 14.5 [368] | 2.0 [51] | 3.0 [1.4] |
| | 500 mL | ⅜ | 6HS500 | 6HD500 | 14.5 [368] | 2.0 [51] | 3.0 [1.4] |
| | 1000 mL | ½ | 8HS1000 | 8HD1000 | 11.0 [279] | 3.5 [89] | 7.25 [3.3] |
| | 2250 mL | ½ | 8HS2250 | 8HD2250 | 17 [432] | 4.0 [102] | 13.4 [6.0] |
| | 3000 mL | ½ | 8HS3000 | 8HD3000 | 22 [559] | 4.0 [102] | 16.75 [7.6] |
| | 1 gal. | ½ | 8HS1G | 8HD1G | 26.75 [679] | 4.0 [102] | 20.6 [9.3] |
| | 2.5 gal. | ½ | — | 8HD2½G | 24.5 [622] | 6.625 [168] | 42.5 [19.9] |
| 4 gal. | ½ | — | 8HD4G | 36 [914] | 6.625 [168] | 61.5 [28] | |
| 316 Stainless Steel, 1800 psig [124 bar] | | | | | | | |
| 1800 [124] | 10 mL | ⅛ | 2HSY10 | 2HDY10 | 4 [102] | 0.625 [16] | 0.125 [0.06] |
| | 30 mL | ¼ | 4HSY30 | 4HDY30 | 4.75 [121] | 1.0 [25] | 0.44 [0.20] |
| | 75 mL | ¼ | — | 4HDY75 | 4.75 [121] | 1.5 [38] | 0.75 [0.34] |
| | 150 mL | ¼ | — | 4HDY150 | 9 [229] | 1.5 [38] | 1.4 [0.6] |
| | 300 mL | ¼ | — | 4HDY300 | 9.5 [241] | 2.0 [51] | 2.0 [0.9] |
| | 500 mL | ¼ | — | 4HDY500 | 14.5 [368] | 2.0 [51] | 2.9 [1.3] |
| | Monel®** | | | | | | |
| 5000 [345] | 95 mL | ¼ | 4HSM95 | 4HDM95 | 5.25 [133] | 1 ²¹ / ₃₂ [42] | 1.5 [0.7] |
| | 150 mL | ¼ | 4HSM150 | 4HDM150 | 6.5 [165] | 1 ²⁹ / ₃₂ [48] | 2.4 [1.0] |
| | 300 mL | ¼ | 4HSM300 | 4HDM300 | 11.75 [298] | 1 ²⁹ / ₃₂ [48] | 4.0 [1.8] |
| | 500 mL | ¼ | 4HSM500 | 4HDM500 | 19.5 [495] | 1 ²⁹ / ₃₂ [48] | 6.13 [2.8] |
| 3500 [241] | 1000 mL | ¼ | 4HSM1000 | 4HDM1000 | 11.5 [292] | 3.5 [89] | 11.4 [5.0] |

* For single-ended applications, order double-ended cylinder with plug part number 502B.

** Standard models are non-DOT rated

Cylinders Accessories & Valves

Collars, Flanges, Caps, Carrying Handles

To enable the user to safely transport pressurized samples, Hoke offers a variety of collar and flange assemblies, protective end caps and carrying handles. Collars can only be assembled at the Hoke factory.

Other accessories can come completely assembled to a cylinder or may be ordered for field installation.

To order, specify the cylinder part number followed by the part number of the accessory.

| CARRYING HANDLES, VALVE PROTECTION END CAPS | | | CYLINDER NUMBER | | DIMENSIONS | |
|---|----------------|----------------------------|-------------------------------------|----------------------------|---|--|
| ORDER BY CATALOG PART NUMBER | | | HIGH PRESSURE | LOW PRESSURE | A OUTSIDE DIAMETER | B |
| COLLAR & FLANGE ASSY. # | END CAP PART # | CARRYING HANDLE KIT PART # | | | | |
| 81744-1 | 3107 | 80228-1 | 4HD300 6HD300 4HD500 | 4HD300 6HD300 4HD500 | 2 in 51 mm | 6 ⁵ / ₈ in 168 mm |
| 81744-1 | 3107 | 80228-1 | 6HD500 | 6HD500 | 2 in 51mm | 6 ⁵ / ₈ in 168 mm |
| 80226-1 | 3107 | 80229-1 | 8HD1000 | 8HD1000 | 3 ¹ / ₂ in 89mm | 6 ⁵ / ₈ in 168 mm |
| 80227-1 | 3107 | 80230-1 | 8HD2250 | 8HD2250 | 4 in 102mm | 6 ⁵ / ₈ in 168 mm |
| 80227-1 | 3107 | 80230-1 | 8HD3000 | 8HD3000 | 4 in 102 mm | 6 ⁵ / ₈ in 168 mm |
| 80227-1 | 3107 | 80230-1 | 8HD1G | 8HD1G | 4 in 102 mm | 6 ⁵ / ₈ in 168 mm |
| 81533-1 | 3107 | 80350-1 | 8HD2 ¹ / ₂ GF | — | 6 ⁵ / ₈ in 168 mm | 6 ⁵ / ₈ in 168 mm |
| 81533-1 | 3107 | 80350-1 | 8HD4GF | — | 8 in 203 mm | 6 ⁵ / ₈ in 168 mm |
| 1756 | 3107 | 80228-1 | 4HDM150 | — | 1 ²⁹ / ₃₂ in 48 mm | 6 ⁵ / ₈ in 168 mm |
| 1756 | 3107 | 80228-1 | 4HDM300 | — | 1 ²⁹ / ₃₂ in 48 mm | 6 ⁵ / ₈ in 168 mm |
| 1756 | 3107 | 80228-1 | 4HDM500 | — | 1 ²⁹ / ₃₂ in 48 mm | 6 ⁵ / ₈ in 168 mm |

All angle pattern valves shown in this catalog can be used with protective end caps. The globe pattern valves 3752M4Y2 shown on page 10 are the only globe pattern valves which can be used with protective end caps.

Dip Tubes

Dip tubes provide a vapor space of the specified volume in cylinders containing liquefied gases, allowing the liquid to expand as the temperature increases. Without adequate vapor space, a small temperature increase can cause the liquid to expand, increasing the pressure dramatically.

Refer to local regulations and other appropriate guidelines for safe cylinder filling limits for your application.

Dip tubes may be ordered in outgates of 10, 20 and 30% to provide a respective filled capacity of 90, 80 or 70%. A 30% outgate tube would "dip" into a cylinder to a point equivalent to the liquid level of a cylinder filled to 70% of its capacity. Dip tubes in other outgates can also be ordered, contact the factory.

To ensure leak-tight performance, dip tubes must be properly welded to a fitting, valve, or relief device.

When ordering dip tubes on valves without cylinders, the cylinder model number or capacity must be identified.

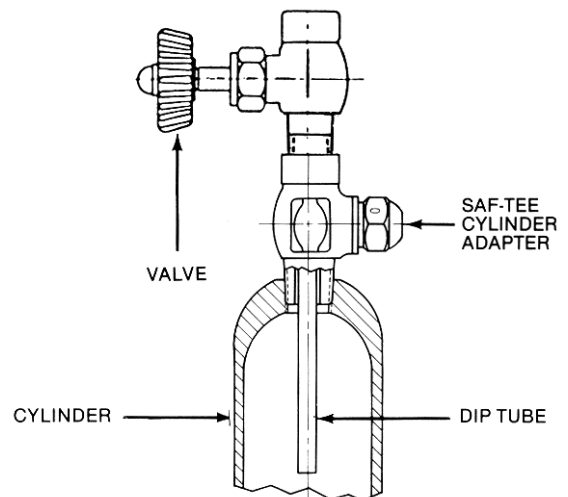
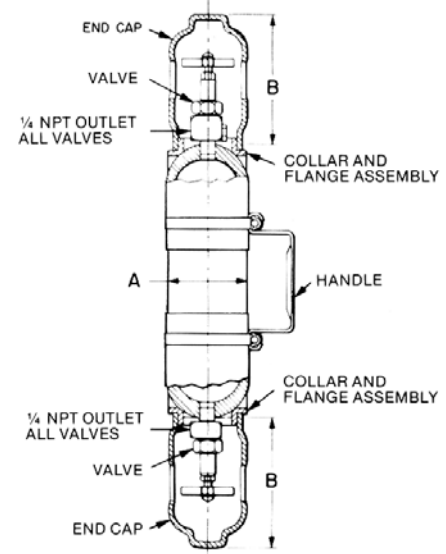

Typical Dip Tube Installation

Cylinder Accessories & Valves

Safety Relief Devices

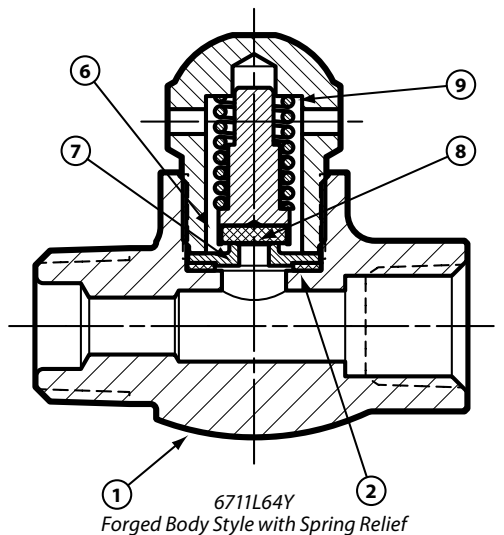
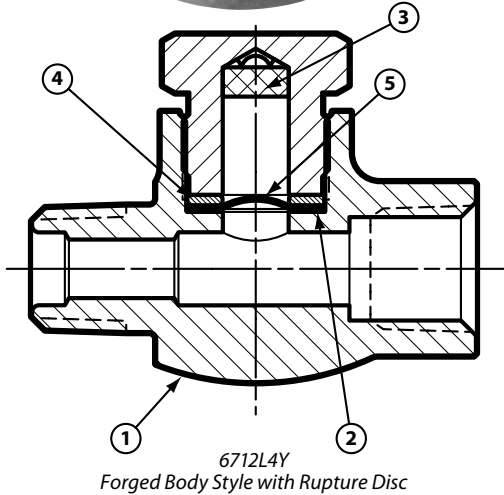

Saf-tee™ relief devices can be used with Hoke sampling cylinders as an inexpensive safety device or as a pipe size adapter for connecting valves in the make-up of cylinder assemblies.

Two basic models are available to satisfy most pressure ranges. Spring relief models are recommended for applications where re-closure is required.

Rupture Disc models are supplied with a pre-bulged rupture disc which provides excellent resistance to a broad range of hold-down plug and rupture disc to prevent damage due to torque transmission during assembly. A safety screen minimizes fragment release through the plug vents. The maximum operating system pressure should be limited to 80% of the nominal rating of the rupture disc for static operating pressure and ambient temperature. It should be limited to 70% if pressure pulsations occur or used at elevated temperature. The burst tolerance is within the ASME code guidelines.

Technical Data

OPERATING TEMPERATURE RANGE: -20° F to +250° F (-29° C to +121° C)

Materials of Construction

| KEY | DESCRIPTION | RUPTURE DISC MODELS | SPRING RELIEF MODELS |
|-----|---------------|---------------------|----------------------|
| 1 | Body | 316SS | 316SS |
| 2 | Gasket | PCTFE | PCTFE |
| 3 | Safety Screen | 316SS | — |
| 4 | Slip Ring | 316SS | — |
| 5 | Rupture Disc | Inconel | — |
| 6 | Seat Holder | 303SS | 303SS |
| 7 | Seat Ring | 316SS | 316SS |
| 8 | Seat | Viton® | Viton® |
| 9 | Spring | 18-8SS | 6712L4Y |

Rupture Disc Models

| INLET NPT MALE | OUTLET NPT FEMALE | ORDER BY NUMBER | ADD CODE LETTER | REPLACEMENT RUPTURE DISC KIT |
|----------------|-------------------|-----------------|--------------------|------------------------------|
| 1/4 | 1/4 | 6712L4Y | D – 1400-1600 psi | SP6712K1 |
| 3/8 | 1/4 | 6712L64Y | G – 1800-2000 psi | SP6712K2 |
| | | | E* – 2600-3000 psi | SP6712K3 |
| | | | F – 3500-4100 psi | SP6712K4** |
| | | | H – 5400-6200 psi | SP6712K5** |

* Normally supplied with DOT 3E-1800 and DOT 3A-1800

** Special order only. Please contact Hoke for details.

Rupture Disc Kits

Replacement rupture disc kits include rupture disc, safety screen, slip ring, gasket and instruction sheet.

Spring Relief Models

| INLET NPT MALE | OUTLET NPT FEMALE | ORDER BY NUMBER | ADD CODE LETTER |
|----------------|-------------------|-----------------|------------------|
| 1/4 | 1/4 | 6711L4Y | C – 350-400 psi |
| 3/8 | 1/4 | 6711L64Y | D* – 540-600 psi |

Ordering Instructions

1. Determine whether the relief range you require is served by a spring relief or a rupture disc model.
2. Order by part number, followed by code of the desired range. For example: No. 6712L4Y.
3. Replacement rupture disc kits may be ordered by part number shown in the rupture disc model chart.

FOR YOUR SAFETY

IT IS SOLELY THE RESPONSIBILITY OF THE SYSTEM DESIGNER AND USER TO SELECT PRODUCTS SUITABLE FOR THEIR SPECIFIC APPLICATION REQUIREMENTS AND TO ENSURE PROPER INSTALLATION, OPERATION AND MAINTENANCE OF THESE PRODUCTS. MATERIAL COMPATIBILITY, PRODUCT RATINGS AND APPLICATION DETAILS SHOULD BE CONSIDERED IN THE SELECTION. IMPROPER SELECTION OR USE OF PRODUCTS DESCRIBED HEREIN CAN CAUSE PERSONAL INJURY OR PROPERTY DAMAGE.

Cylinder Valves

1700 Series Heavy Duty Cylinder Valves

Heavy duty compact line of 316 stainless steel and Monel® forged body globe pattern valves features an integral bonnet suitable for ¼" and ¾" NPT ended cylinders.



1711L4Y

Features

- Dyna-Pak packing provides a leak-tight seal with low operating torque
- Packing below stem threads prevents fluid from contacting threads
- Non-rotating hardened 17-4PH stainless steel or replaceable PCTFE stem tip prevents galling and extends valve life
- Hardened 450 stainless steel or Monel® combination packing nut and thread gland for long stem thread cycle life
- Lock-nut secures packing nut, preventing accidental removal
- Flat wrench pads on body for easy valve installation
- Integral stem backstop for added safety

Technical Data

| | |
|-----------------------------------|--|
| MAXIMUM OPERATING PRESSURE | 6000 psig [414 barg] |
| TEMPERATURE RANGE | -65° F to +450° F [-54° C to +232° C] (metal stem tip) -20° F to +250° F [-29° C to +121° C] (PCTFE stem tip) |
| ORIFICE SIZE | 0.187 |
| Cv FACTOR | 0.45 |

Materials of Constructions

| DESCRIPTION | 316SS Valves | Monel® Valves |
|-------------------------|------------------|-------------------|
| BODY | 316SS | Monel® |
| STEM | 316SS | Monel® |
| STEM TIP | SOFT | PCTFE |
| | HARD | 17-4 PHSS |
| DYNA-PAK PACKING | TFE/316SS Wafers | TFE/Monel® Wafers |
| HANDLE | Aluminum | Aluminum |

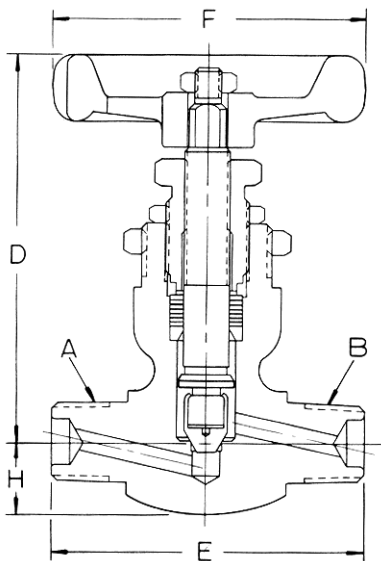

1711[]

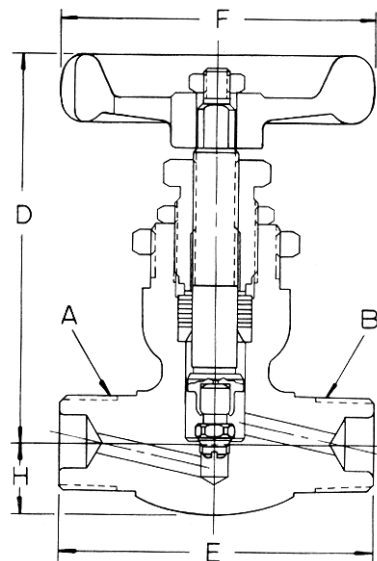

1751[]

FOR YOUR SAFETY

IT IS SOLELY THE RESPONSIBILITY OF THE SYSTEM DESIGNER AND USER TO SELECT PRODUCTS SUITABLE FOR THEIR SPECIFIC APPLICATION REQUIREMENTS AND TO ENSURE PROPER INSTALLATION, OPERATION AND MAINTENANCE OF THESE PRODUCTS. MATERIAL COMPATIBILITY, PRODUCT RATINGS AND APPLICATION DETAILS SHOULD BE CONSIDERED IN THE SELECTION. IMPROPER SELECTION OR USE OF PRODUCTS DESCRIBED HEREIN CAN CAUSE PERSONAL INJURY OR PROPERTY DAMAGE.

Dimensions & How to Order 1700 Series Globe Pattern Valves

| BASIC MATERIAL | STEM TIP | END CONNECTIONS | | ORDERING NUMBER | DIMENSIONS inch (mm) | | | |
|----------------|----------|-----------------|--------------|-----------------|----------------------|---------|---------|--------|
| | | INLET A | OUTLET B | | D | E | F | H |
| 316 SS | Metal | ¼ NPT Male | ¼ NPT Male | 1711M4Y | 3 (76) | 2⅜ (56) | 2⅞ (54) | ⅞ (12) |
| | Metal | ¼ NPT Male | ¼ NPT Female | 1711L4Y | 3 (76) | 2⅞ (54) | 2⅞ (54) | ⅞ (12) |
| | PCTFE | ¾ NPT Male | ¾ NPT Male | 1751M6Y | 3 (76) | 2⅜ (56) | 1⅞ (48) | ⅞ (12) |
| Monel® | Metal | ¼ NPT Male | ¼ NPT Male | 1711M4M | 3 (76) | 2⅜ (56) | 2⅞ (54) | ⅞ (12) |
| | PCTFE | ¼ NPT Male | ¼ NPT Male | 1751M4M | 3 (76) | 2⅜ (56) | 2⅜ (56) | ⅞ (12) |

Dimensions are for reference only and are subject to change

Cylinder Valves

1900 Series Cylinder Valves



1935L64Y

This durable line of angle pattern valves features a low profile shrouded handle which protects the valve against damage. Dyna-Pak TFE wafer packing provides a leak tight seal with low operating torque even at 6000 psi (414 bar) pressure.

Features

- 316SS or Monel construction
- Low profile aluminum shrouded stem handle protects stem against damage
- Dyna-Pak packing provides leak tight seal with low operating torque
- Packing below the stem threads prevents process fluid from contacting stem threads
- Non-rotating hardened 17-4PH stainless steel or replaceable PCTFE stem tip prevents galling and extends valve life
- Hardened 450 stainless steel combination packing nut and thread gland for long stem thread cycle life
- Integral stem backseat provides added safety and prevents accidental removal of stem
- Variety of end connections satisfy most cylinder valve applications
- Bonnet lock prevents accidental removal of threaded bonnet
- Angle flow pattern
- Lock-nut secures packing nut against accidental removal
- Flat wrench pads on body for easy valve installation
- Integral stem backstop for added safety

| Technical Data | |
|-----------------------------|--|
| MAXIMUM OPERATING PRESSURE | 6000 psig (414 bar) |
| OPERATING TEMPERATURE RANGE | -65° F to +450° F [-54° C to +232° C] (metal stem tip) -20° F to +250° F [-29° C to +121° C] (PCTFE stem tip) |
| ORIFICE | Metal Stem Tip - 0.156 PCTFE Stem Tip - 0.187 |
| CV FACTOR | Metal Stem Tip - 0.42 PCTFE Stem Tip - 0.63 |

| Materials of Construction | | |
|---------------------------|------------------|---------------------|
| DESCRIPTION | 316SS VALVES | MONEL VALVES |
| Body | 316SS | Monel® |
| Stem | 316SS | Monel® |
| Stem Tip | Soft | PCTFE |
| | Hard | 17-4 PHSS Monel® |
| Packing (Dyna-Pak) | TFE/316SS Wafers | TFE/Monel® Wafers |
| Handle | Aluminum | Aluminum |

Handle Turns vs Cv

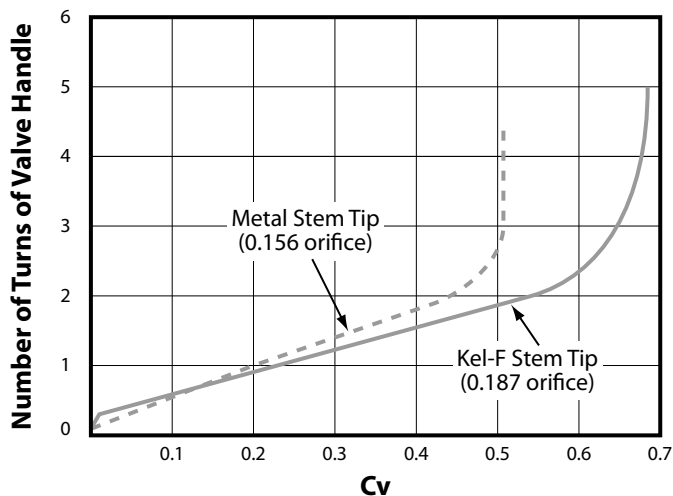

Pressure Temperature Curve

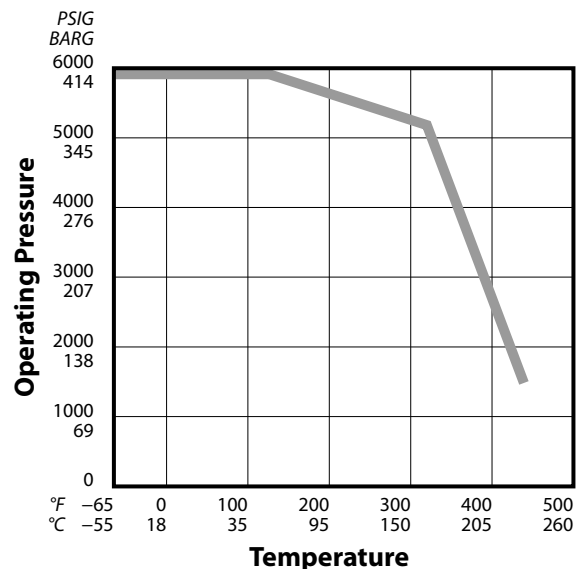

Cylinder Valves

1900 Series Cylinder Valves

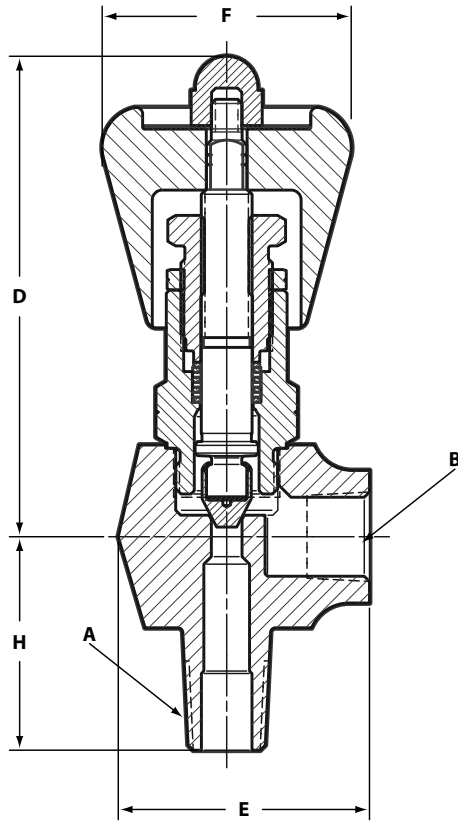

1925L[Y]

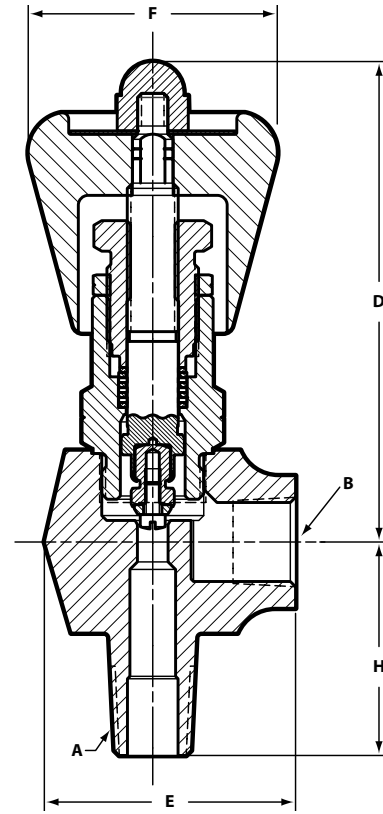

1965L[]

| Dimensions & How to Order 1900 Series Angle Pattern Valves | | | | | | | | |
|--|----------|-----------------|--------------|-----------------|----------------------|---------|---------|---------|
| BASIC MATERIAL | STEM TIP | END CONNECTIONS | | ORDERING NUMBER | DIMENSIONS, IN. [MM] | | | |
| | | INLET A | OUTLET B | | D | E | F | H |
| 316 SS | Metal | ¼ NPT Male | ¼ NPT Female | 1925L4Y | 3¾ [81] | 1½ [38] | 1¾ [44] | 1⅝ [33] |
| | PCTFE | ¼ NPT Male | ¼ NPT Female | 1965L4Y | 3¾ [81] | 1½ [38] | 1¾ [44] | 1⅝ [33] |
| | Metal | ⅜ NGT Male* | ¼ NPT Female | 1925L64Y | 3¾ [81] | 1½ [38] | 1¾ [44] | 1⅜ [35] |
| | PCTFE | ⅜ NGT Male* | ¼ NPT Female | 1965L64Y | 3¾ [81] | 1½ [38] | 1¾ [44] | 1⅜ [35] |
| Monel | PCTFE | ¼ NPT Male | ¼ NPT Female | 1965L4M | 3¾ [81] | 1½ [38] | 1¾ [44] | 1⅝ [33] |

* NGT Male Ended Valves: Screw thread standard per Federal Services Handbook H-28, section 9. These threads allow longer thread engagement into the cylinder.

Dimensions are for reference only and are subject to change

FOR YOUR SAFETY

IT IS SOLELY THE RESPONSIBILITY OF THE SYSTEM DESIGNER AND USER TO SELECT PRODUCTS SUITABLE FOR THEIR SPECIFIC APPLICATION REQUIREMENTS AND TO ENSURE PROPER INSTALLATION, OPERATION AND MAINTENANCE OF THESE PRODUCTS. MATERIAL COMPATIBILITY, PRODUCT RATINGS AND APPLICATION DETAILS SHOULD BE CONSIDERED IN THE SELECTION. IMPROPER SELECTION OR USE OF PRODUCTS DESCRIBED HEREIN CAN CAUSE PERSONAL INJURY OR PROPERTY DAMAGE.

Cylinder Valves

2400 Series 1/2" Cylinder Valves



2464L84Y
with rupture disc

2400 Series 316 stainless steel, forged body angle pattern valves, come with a union bonnet for increased safety and ease of maintenance.

Available with pressure rupture discs or spring relief devices as an integral part of the valve.

Features

- Forged body union bonnet design for ease of maintenance and maximum reliability
- Non-rotating hardened 17-4PH stainless steel tip prevents galling and extends valve life
- Dyna-Pak packing below stem threads prevents lubricant washout & contamination of process fluids
- Stem backseat provides added safety
- Available with integral rupture disc or spring relief

Technical Data

| | |
|-----------------------------------|--|
| MAXIMUM OPERATING PRESSURE | 5000 psig [345 barg] |
| TEMPERATURE RANGE | Metal stem tip: -40° F to +350° F (-40° C to +177° C) TFE stem tip: -20° F to +250° F (-29° C to +121° C) All burst discs & spring relief devices: -20° F to +250° F (-29° C to +121° C) |
| ORIFICE SIZE | 0.312 |
| Cv FACTOR | 2.2 |

Materials of Constructions

| | |
|--------------------------|--------|
| BODY & BONNET | 316SS |
| STEM | 17-4PH |
| THREAD GLAND | 416SS |
| PACKING NUT | 303SS |
| RING GLAND | 303SS |



2466L84Y
with spring relief



2462L84Y

Cylinder Valves

Valves with Rupture Discs

| INLET | OUTLET | ORDER BY PART NUMBER | | ADD CODE LETTER | RUPTURE DISC KITS |
|--------------------|----------------------|----------------------|----------------|---------------------|-------------------|
| | | TEFLON® PACKING | | | |
| | | TEFLON® STEM TIP | METAL STEM TIP | | |
| 1/2 NGT Male | 1/4 NPT Female | 2464L84Y | 2424L84Y | D 1400–1600 psi | SP6712K1 |
| | | | | G 1800–2000 psi | SP6712K2 |
| | | | | E* 2600–3000 psi | SP6712K3 |
| | | | | F 3500–4100 psi | SP6712K4** |
| | | | | H 5400–6200 psi | SP6712K5** |

* Normally supplied with DOT 3E-1800 and DOT 3A-1800

** Special order only. Please contact Hoke factory.

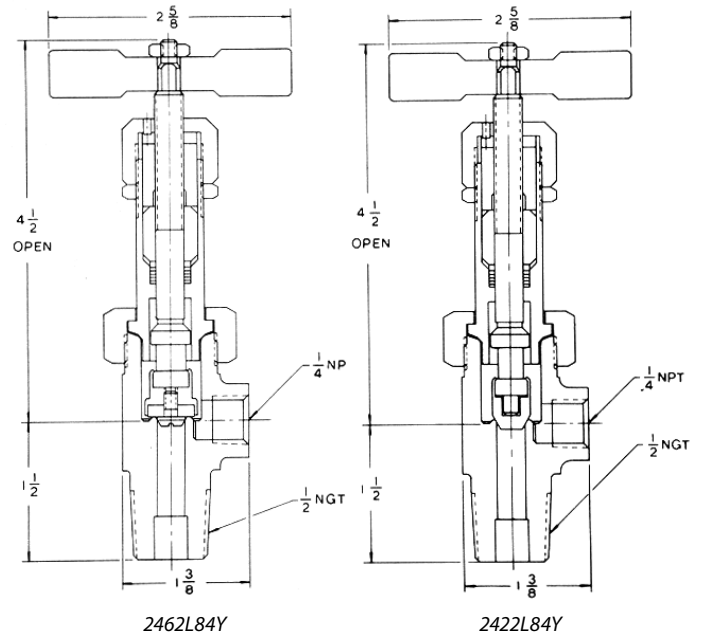

Valves without Relief Devices

| INLET | OUTLET | ORDER BY PART NUMBER | |
|--------------------|----------------------|----------------------|----------------|
| | | TEFLON® PACKING | |
| | | TEFLON® STEM TIP | METAL STEM TIP |
| 1/2 NGT Male | 1/4 NPT Female | 2462L84Y | 2422L84Y |

Valves with Spring Relief Devices

| INLET | OUTLET | ORDER BY PART NUMBER | | ADD CODE LETTER |
|--------------------|----------------------|----------------------|----------------|-----------------|
| | | TEFLON® PACKING | | |
| | | TEFLON® STEM TIP | METAL STEM TIP | |
| 1/2 NGT Male | 1/4 NPT Female | 2466L84Y | 2426L84Y | C 350–400 psi |
| | | | | D* 540–600 psi |

* Normally supplied with DOT 38-400

Ordering Instructions for Valves with Relief Devices

1. Determine whether the relief range you require is served by a spring relief or a rupture disc model.
2. Order by part number, followed by code of the desired range. For example: No. 2424L84YD.

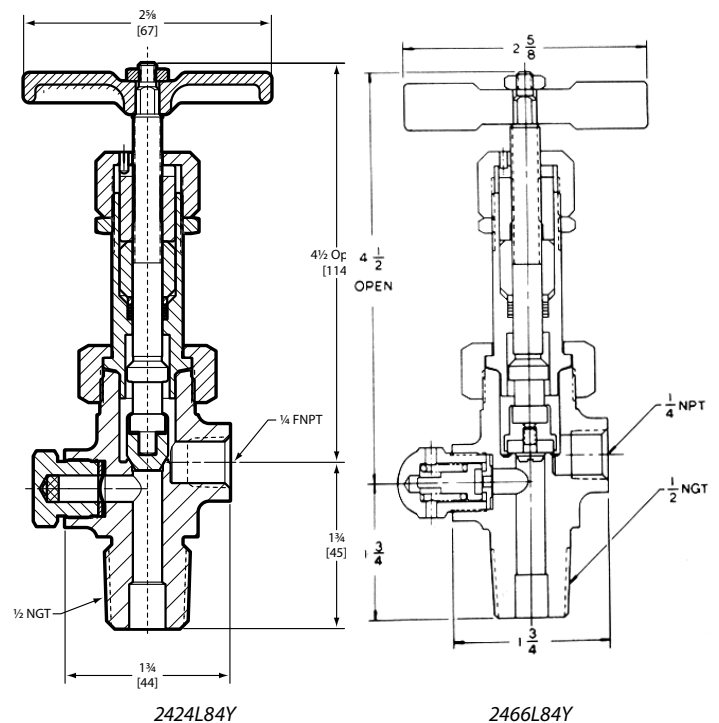

Cylinder Valves

3700 & 3800 Series Cylinder Valves



Angle 3802L4Y

The 3700 & 3800 Series forged body cylinder valves are supplied in stainless steel for cylinders with 1/8" through 3/8" NPT threads.

Features

- Compact size for restricted areas
- Dyna-Pak packing provides a leak-tight seal and low operating torque
- Integral bonnet design
- Ergonomic black ABS plastic handle
- Flat wrench pads on body for easy valve installation
- Replaceable PCTFE stem tip or integral metal stem tip
- Choice of 303 or 316 stainless steel construction
- Globe or angle flow patterns
- 3752M4Y[] Series are designed for use with cylinder protective caps and collars on 300 and 500 mL size cylinders. Low profile and extended end allows the valve and handwheel to clear the cap and cylinder collar

Technical Data

| | |
|------------------------------------|--|
| MAXIMUM OPERATING PRESSURE: | 5000 psig (345 bar) |
| TEMPERATURE RANGE: | -65° F to +450° F (metal stem tip) -20° F to +250° F (PCTFE stem tip) |
| ORIFICE SIZES: | 0.060, 0.170, 0.219 |
| Cv FACTOR: | 0.07 to 0.55 |



Globe 3752M4Y1

Materials of Construction

| DESCRIPTION | 303SS VALVES | 316SS VALVES |
|---------------------|---------------|---------------|
| Body | 303SS | 316SS |
| Stem | 316SS | 316SS |
| Stem Tip (Softseat) | PCTFE | PCTFE |
| Dyna-Pak Packing | Teflon®/316SS | Teflon®/316SS |
| Handle* | ABS | ABS |

* 303 stainless steel metal handle is provided on models 3752M4Y[]

Handle Turns vs. Cv

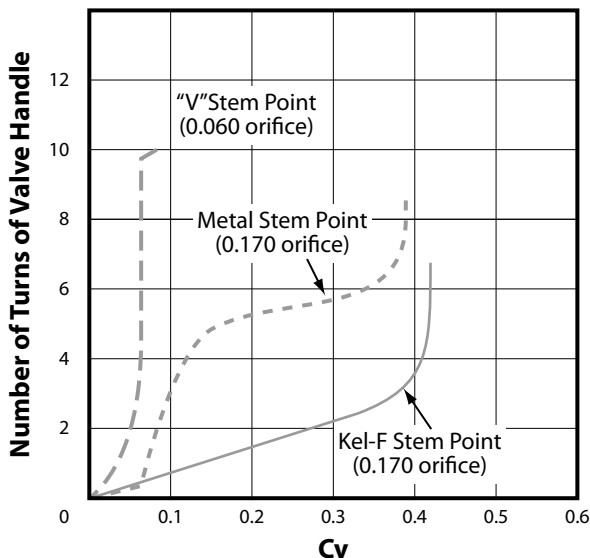

Pressure-Temperature Curve

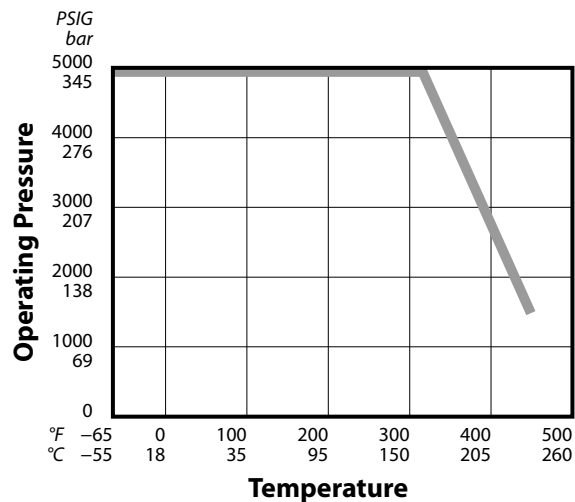

Cylinder Valves

3700 & 3800 Series Cylinder Valves

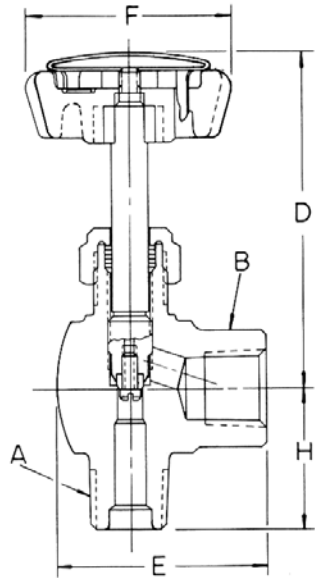

Angle 3862L64Y

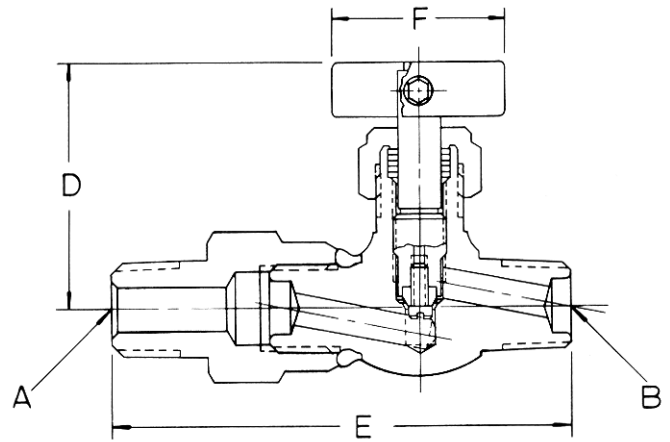

Globe 3752M4Y1

| Dimensions & How to Order 3700 & 3800 Series Cylinder Valves | | | | | | | | | |
|--|------|--------------|---|---|-----------------|--------------------------------------|-------------------------------------|-------------------------------------|-------------------------------------|
| BASIC MATERIAL | CV | STEM TIP | END CONNECTIONS | | ORDERING NUMBER | DIMENSIONS inch [mm] | | | |
| | | | INLET A | OUTLET B | | D | E | F | H |
| Globe Pattern Orifice Size 0.060 | | | | | | | | | |
| 316 SS | 0.07 | Metal V-stem | ¼ NPT Male | ¼ NPT Male | 3732M4Y | 2 ³ / ₁₆ [56] | 1 ³ / ₄ [44] | 1 ¹ / ₁₆ [36] | 25/64 [10] |
| Globe Pattern Orifice Size 0.170 | | | | | | | | | |
| 303 SS | 0.35 | PCTFE | ¼ NPT Male | ¼ NPT Male | 3752M4S | 2 ¹ / ₈ [54] | 2 [51] | 1 ¹ / ₁₆ [36] | 3 ⁸ / ₁₀ [10] |
| | | PCTFE | ¼ NPT Male | ¼ NPT Female | 3852L4S | 2 ¹ / ₁₆ [68] | 1 ⁷ / ₈ [48] | 1 ⁷ / ₆₄ [36] | ½ [13] |
| 316 SS | 0.35 | Metal | ¼ NPT Male | ¼ Gyrolok | 3712H4Y | 2 ¹ / ₈ [54] | 1 ⁷ / ₈ [48] | 1 ¹ / ₁₆ [36] | 3 ⁸ / ₁₀ [10] |
| | | PCTFE | ¼ NPT Male | ¼ Gyrolok | 3752H4Y | 2 ¹ / ₈ [54] | 1 ⁷ / ₈ [48] | 1 ¹ / ₁₆ [36] | 3 ⁸ / ₁₀ [10] |
| | | Metal | ¼ NPT Male | ¼ NPT Male | 3712M4Y | 2 ¹ / ₈ [54] | 2 [51] | 1 ¹ / ₁₆ [36] | 3 ⁸ / ₁₀ [10] |
| | | PCTFE | ¼ NPT Male | ¼ NPT Male | 3752M4Y | 2 ¹ / ₈ [54] | 2 [51] | 1 ¹ / ₁₆ [36] | 3 ⁸ / ₁₀ [10] |
| | | PCTFE | ¼ NPT Male | ¼ NPT Male | 3752M4Y2* | 1 ¹³ / ₁₆ [46] | 2 ³ / ₄ [70] | 1 [25] | — |
| | | PCTFE | 3 ⁸ / ₁₆ NPT Male | 3 ⁸ / ₁₆ NPT Male | 3852M6Y | 2 ¹³ / ₁₆ [71] | 1 ⁷ / ₈ [48] | 1 ⁷ / ₈ [48] | ½ [13] |
| | | PCTFE | ½ NPT Male | ¼ NPT Male | 3752M4Y1* | 1 ¹³ / ₁₆ [46] | 3 [76] | 1 [25] | — |
| Globe Pattern Orifice Size 0.219 | | | | | | | | | |
| 316 SS | 0.55 | Metal | 3 ⁸ / ₁₆ NPT Male | 3 ⁸ / ₁₆ NPT Male | 3812M6Y | 2 ²⁵ / ₃₂ [71] | 2 ⁹ / ₁₆ [65] | 1 ⁷ / ₈ [48] | 3 ¹ / ₆₄ [12] |
| Angle Pattern Orifice Size 0.170 | | | | | | | | | |
| 316 SS | 0.5 | Metal | ¼ NPT Male | ¼ Gyrolok | 3722H4Y | 2 ¹ / ₈ [54] | 1 ⁹ / ₃₂ [40] | 1 ¹ / ₁₆ [36] | 7 ⁸ / ₁₀ [22] |
| | | Metal | ¼ NPT Male | ¼ NPT Female | 3802L4Y | 2 ¹ / ₁₆ [68] | 1 ⁷ / ₆₄ [36] | 1 ¹ / ₁₆ [36] | 3 ¹ / ₃₂ [25] |
| | | PCTFE | ¼ NPT Male | ¼ NPT Female | 3862L4Y | 2 ¹ / ₁₆ [68] | 1 ⁷ / ₆₄ [36] | 1 ¹ / ₁₆ [36] | 3 ¹ / ₃₂ [25] |
| | | Metal | 3 ⁸ / ₁₆ NPT Male | ¼ NPT Female | 3802L64Y | 2 ¹ / ₁₆ [68] | 1 ⁷ / ₆₄ [36] | 1 ¹ / ₁₆ [36] | 3 ¹ / ₃₂ [25] |
| | | PCTFE | 3 ⁸ / ₁₆ NPT Male | ¼ NPT Female | 3862L64Y | 2 ¹ / ₁₆ [68] | 1 ⁷ / ₁₆ [36] | 1 ¹ / ₁₆ [36] | 1 [25] |

* Models 3752M4Y[] are designed for use with cylinder protective caps and collars on 300 and 500 ml. cylinders. Dimensions are for reference only and are subject to change

FOR YOUR SAFETY

IT IS SOLELY THE RESPONSIBILITY OF THE SYSTEM DESIGNER AND USER TO SELECT PRODUCTS SUITABLE FOR THEIR SPECIFIC APPLICATION REQUIREMENTS AND TO ENSURE PROPER INSTALLATION, OPERATION AND MAINTENANCE OF THESE PRODUCTS. MATERIAL COMPATIBILITY, PRODUCT RATINGS AND APPLICATION DETAILS SHOULD BE CONSIDERED IN THE SELECTION. IMPROPER SELECTION OR USE OF PRODUCTS DESCRIBED HEREIN CAN CAUSE PERSONAL INJURY OR PROPERTY DAMAGE.

Formed Sampling Cylinders

How to Collect Samples from Process Lines

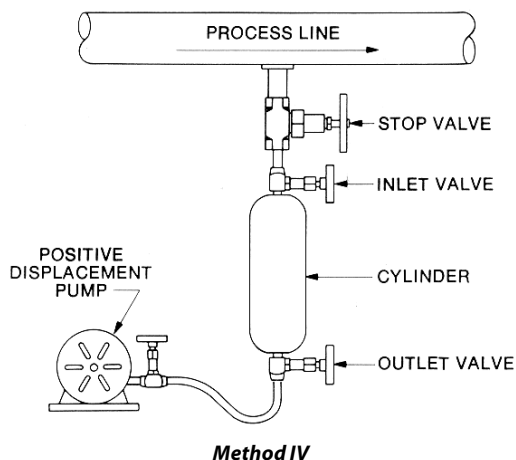
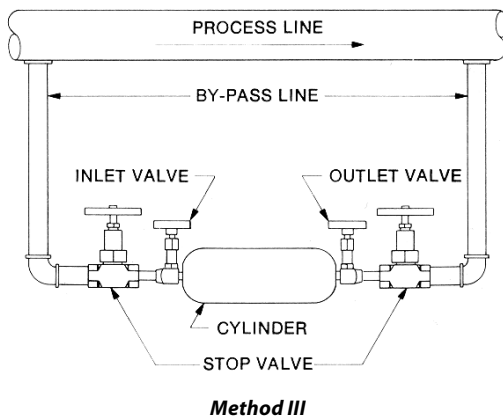
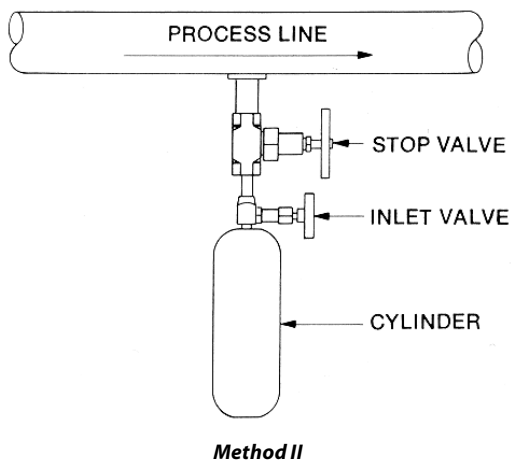
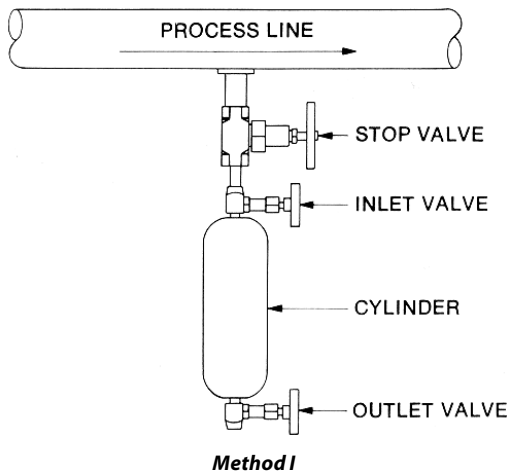

It is often difficult to obtain pure samples of process fluids for laboratory analysis. To insure accuracy and safety of your sample, DOT regulations, elimination of contaminants, cost and simplicity of operation must be considered.

Here are four methods of collecting samples which we as manufacturers and suppliers of sampling cylinders and valves have seen successfully used.

Method I: Water Displacement

1. Use a double-ended Hoke cylinder (either the LD or HD styles depending upon pressure requirements) with sufficient capacity and equip it with suitable Hoke valves.
2. Fill the cylinder with water so that all contaminants in the cylinder are removed by displacement.
3. Attach cylinder to process line and open process line stop valve.
4. Open both valves on sampling cylinder, the inlet valve wider than the outlet and allow the process fluid to displace the water in cylinder.
5. When cylinder is filled (this is indicated when process fluid begins flowing out cylinder outlet valve), close outlet valve and then both inlet and stop valves and remove cylinder from process line.
6. Transport cylinder to laboratory and bleed off samples as required.

Method II: Evacuate Cylinder by Vacuum

1. Use either a double or single ended cylinder with valves, preferably packless type. Helium leak tested to insure leak tightness.
2. Evacuate the cylinder to remove contaminants.
3. Attach cylinder to process line.
4. Open inlet valve and draw off desired sample.
5. Close valve and remove cylinder from process line.
6. Draw samples from cylinder as required on mass spectrometer.

Method III: In Line By-pass of Process Line

1. Establish by-pass line or parallel line to main process line with facilities to insert sampling cylinder.
2. Insert double-ended cylinder in by-pass line.
3. Open both inlet and outlet cylinder valves wide and allow process fluid to flow through by-pass line and cylinder.
4. Permit flow to continue running until accurate sample is established.
5. Close valves and remove cylinder from process line.
6. Draw sample from cylinder when required.

Method IV: Positive Displacement

1. Use a double-ended cylinder equipped with suitable valves.
2. Attach one end of the cylinder to the process line and the other to a positive displacement pump which draws uniformly over a period of time.
3. Open process line and cylinder valves and begin drawing off a uniform sample over an established period of time.
4. When time period is completed, close valves and remove cylinder from process line.
5. Sample gathered is an example of fluid passed through process line over a given period.

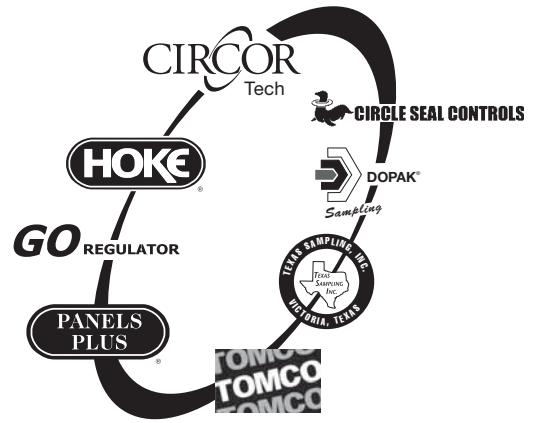
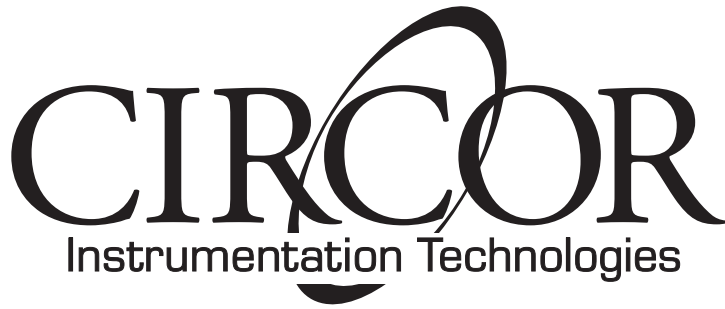

Hoke • GO Regulator • Tomco • CIRCOR Tech

405 Centura Court • PO Box 4866 (29305)
Spartanburg, SC 29303
Tel (864) 574-7966 • Fax (864) 587-5608
www.circortechnologies.com

Hoke Controls / Panels Plus

2054 Francis St.
Ontario, CA 91761
Tel (909) 923-3770
Fax (909) 923-2550
www.circor-panelsplus.com

Texas Sampling, Inc

3706 Rio Grande
Victoria, Texas 77901
Tel (361) 575-8087
Fax (361) 575-8157
www.texassampling.com

**CIRCOR Instrumentation
Technologies**

Central Europe
Leeuwenhoekweg 24
2661 CZ Bergschenhoek
The Netherlands
Tel +31 10 4206011 • Fax +31 10 4566774
www.circortechnologies.com

Dopak Inc.

9572 Kempwood
Houston, Texas 77080
Tel (713) 460-8311
Fax (713) 460-8578
www.dopak.com

**Circle Seal
Controls**

2301 Wardlow Circle
Corona, CA 92880
Tel (951) 270-6200
Fax (951) 270-6201
www.circlesealcontrols.com

Hoke GmbH

Weitzesweg 11
Postfach 1541
D-61118 Bad Vilbel-Dortelweil
Germany
Tel +49 6101 82 56 0
Fax +49 6101 82 56 40
www.hoke.de

CIRCOR Instrumentation Technologies

CIRCOR Instrumentation Technologies (CIT) is a product group of CIRCOR International (NYSE: CIR), specializing in fluid process control solutions with orifice sizes typically up to 1". Our main product lines include ball, needle, packless, diaphragm, solenoid, and metering valves, pressure regulators, quick couplers, Gyrolok® compression tube fittings, and fully integrated sampling systems.

CIT markets primarily to the petrochemical, refining, power generation, food and beverage, semiconductor, and pharmaceutical industries, and to OEM's. CIT separates itself from the competition by offering highly engineered components manufactured to exacting standards and a variety of custom options.