



# The Facts About Interchangeability and Intermixability

<b>Index</b>	
History of HOKE Gyrolok®	1
Background	1
Commitment to Customer	1
Intermixability	2
Interchangeability	2
Positions	2
Guarantee	3
Features & Benefits	4



gyrolok® tube fittings

**HOKE Incorporated**  
405 Centura Court • PO Box 4866 (29305) • Spartanburg, SC 29303  
Phone (864) 574-7966 Fax (864) 587-5608  
www.hoke.com • sales@hoke.com

# Interchangeability and Intermixability

## *History of HOKE Gyrolok®*

---

HOKE Incorporated was founded in 1925 and began manufacturing valve products, which were the forerunners of today's valve products, in the 1940's.

During the 1950's, HOKE had a licensing agreement with the Crawford Fitting Company, the manufacturer of Swagelok® fittings. That agreement permitted HOKE to manufacture and supply its valves with Swagelok® fitting ends. In the early 1960's, once that agreement had expired, HOKE had several decisions to make regarding how to continue supplying valves with flareless tube fitting ends.

In some ways it would have been easy for HOKE to offer a virtual copy (once patents had run out) of the Swagelok® fitting. HOKE chose not to do this, however. Why? Because our experiences with the Swagelok® fitting combined with customer feedback indicated that, even though the Swagelok® fitting was a good one, there were opportunities to improve upon it.

Those improvements can be found in the HOKE Gyrolok® tube fitting. **HOKE Gyrolok® Fittings have a unique design offering added features and value to our customers available on no other fitting product.**



## *Background*

---

Users of flareless tube fittings, like consumers of any product, are always looking for the best product value available. If a fittings user determines that another brand offers better value, one must consider the questions of Interchange/Intermix. The terms *interchange* or *intermix* refer to the use of components of different manufacturers within one fitting assembly. Some of the questions we will address while focusing on HOKE Gyrolok® and Swagelok® fittings are:

- Should it be done?
- What are the positions of different manufacturers?
- What is HOKE's position?

## *HOKE's Commitment to the Customer*

---

Not only is HOKE Gyrolok® a precision engineered and manufactured fitting, but HOKE's commitment to quality and to the customer assures that the HOKE Gyrolok® fitting is the finest product available.

At HOKE, the customer comes first. To that end, HOKE products are designed to provide the maximum in safety and value to the user. HOKE's world class quality – exemplified by HOKE's holding of American Society of Mechanical Engineers (ASME) Quality System Certificates and ISO 9001 Certification – assures that our designs are translated into the finest products available.

To ensure that our customers always receive the highest quality products available, HOKE is committed to a philosophy of continuous improvement. To this end, HOKE has embraced the concepts of *Total Quality Management* and *Statistical Process Control*.

Total Quality Management is a customer focused management process that drives continuous improvement in quality, cost, and delivery through the creative involvement of all employees. Statistical Process Control is one of the key mechanisms by which this process is accomplished.

Through continuous improvement, HOKE is dedicated to providing our customers the safest and most economical products available.

# Interchangeability and Intermixability

To help understand the subject we will define the terms *intermix* and *interchange* as follows:

## Intermixability

Definition:

*Intermix* is the random mixing of components of different manufacturers.

### HOKE Position:

As described on the following pages HOKE has chosen to produce a unique fitting with distinct user-oriented advantages. Having chosen to be better by being different HOKE Gyrolok® also chose not to be randomly intermixable. The commitment to provide maximum benefits to the user precludes HOKE from recommending random mixing of components.

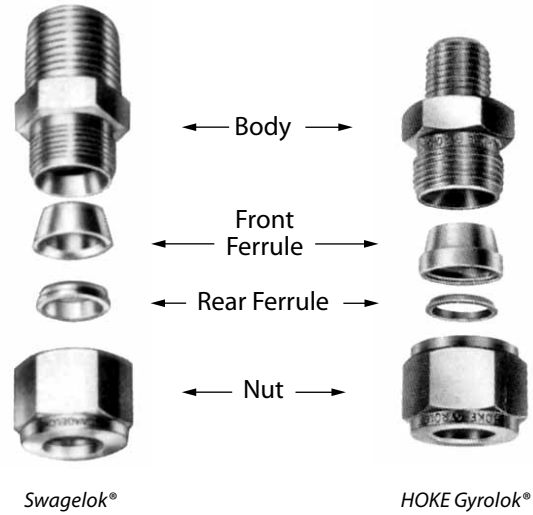

## Interchangeability

Definition:

*Interchange* is more specifically defined as the use of one manufacturer's nut and ferrule system with another manufacturer's body.

Interchangeability situations are encountered when a user must replace a portion of a system. In this case a user may have a fitting ended valve he wants to retain while replacing the tubing coming into it. Interchangeability allows him to replace the tubing, which has attached nuts and ferrules, but still retain the use of the valve. He would then assemble new tubing with new nuts and ferrules of another manufacturer to the fitting-ended valve already in place. The converse could equally be true. Interchangeability thus addresses real functional needs while giving the user the opportunity to achieve maximum safety and value.

### HOKE Position:

HOKE, while offering superior product design, is nonetheless able to guarantee functional interchangeability of the HOKE Gyrolok® and Swagelok® fittings.



Fitting Ended Valve



Ferrules Nut Tubing

## Positions of Other Manufacturers

Most flareless tube fitting manufacturers endorse intermixability and/or interchangeability with specific manufacturers. We will not focus on these manufacturers but rather on the one notable exception, the Swagelok® Company. Swagelok® does not recommend interchangeability or intermixability.

A fitting user who doesn't investigate further might then fail to be diligent in assuring that he is getting the maximum value and safety from his fitting product.

And the **maximum** in value and safety is what the user of HOKE Gyrolok® Flareless Tube Fittings receives.

# Interchangeability and Intermixability

## *The Interchangeability Guarantee*

HOKE's experience in manufacturing HOKE valves with Swagelok® ends enables us to ensure that the Gyrolok® fitting body is dimensioned similarly to Swagelok® in key areas, highlighted below, and then precision manufactured.

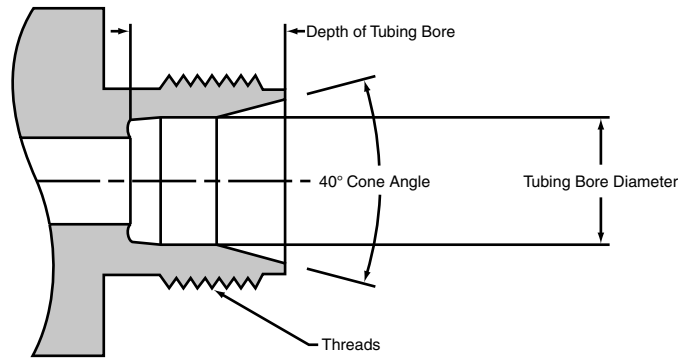

The result is that HOKE Incorporated is able to guarantee the functional interchangeability of Gyrolok® Tube Fittings with similar fittings of certain other manufacturers, including Swagelok®, Parker A-lok® and Parker CPI™. Specifically, whenever Gyrolok® and fittings of certain other manufacturers are interchanged by using one manufacturer's nut and ferrule system with the other's body, HOKE will guarantee this interchanged fitting to effect a safe, secure leak tight seal provided there is no deficiency in parts not supplied by HOKE. Properly interchanged product is covered by HOKE Incorporated's standard warranty.

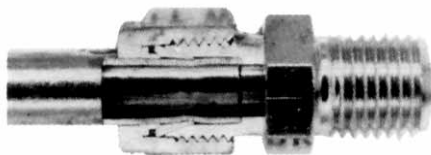

*Gyrolok® body with Swagelok® nut and ferrule – 1 turn*

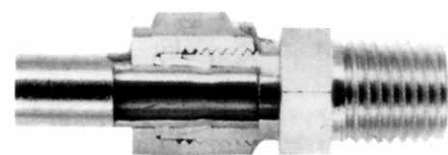

*Swagelok® body with Gyrolok® nut and ferrule – 1 turn*

The interchange process, as well as routine component replacement, is most safely and easily accomplished by use of HOKE Gyrolok's® unique SCNF Safety Changer which contains nut and ferrule sets ready for assembly to Gyrolok® or Swagelok® fitting bodies.

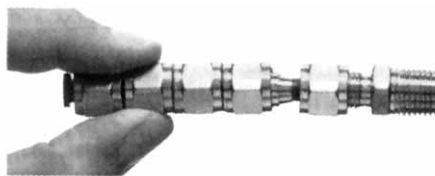

As many customers have already discovered, interchangeability is the safe way to combine Gyrolok® and Swagelok® components.

Interchangeability allows the current Swagelok® fitting user to enjoy the unique benefits of HOKE Gyrolok® fittings.

HOKE Gyrolok® interchangeability is not just limited to Swagelok®. A written statement of HOKE's Position on Interchangeability with specific manufacturers is available on request from your local HOKE stocking distributor.

## *For Your Safety*

It is solely the responsibility of the system designer and user to select products suitable for their specific application requirements and to ensure proper installation, operation, and maintenance of these products. Material compatibility, product ratings and application details should be considered in the selection. Improper selection or use of products described herein can cause personal injury or property damage.

*Gyrolok® is a registered trademark of HOKE Incorporated.  
Swagelok® is a registered trademark of Swagelok Company.  
Hastelloy® is a registered trademark of Haynes International, Inc.  
Monel® is a registered trademark of Special Metals Corporation.*

# Interchangeability and Intermixability

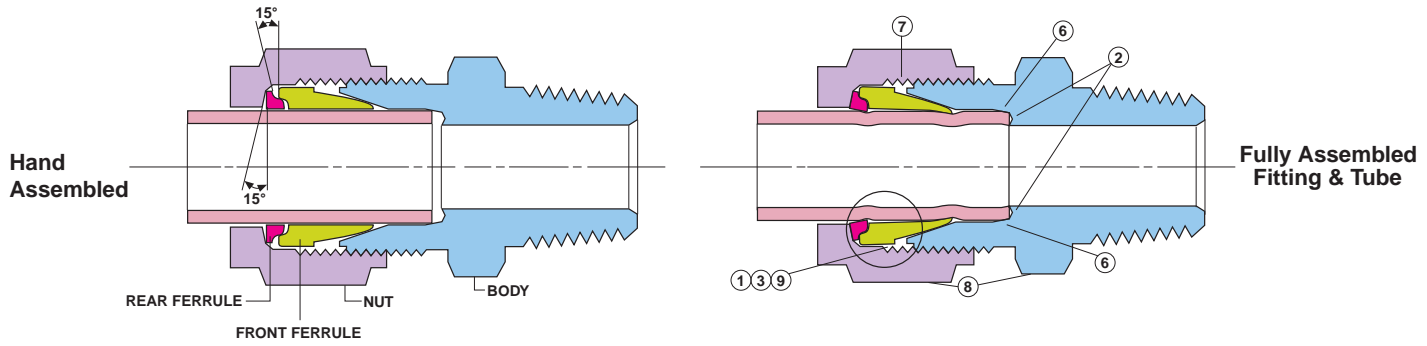

FEATURES	EXPLANATION	BENEFITS
<b>1. CONTROLLED FERRULE DRIVE</b>	Roll-in locking action of rear ferrule: During fitting makeup, 15° angles close — between the rear ferrule and nut, and between the rear ferrule and front ferrule — thus preventing overstressing of tubing or excessively reducing tubing inside diameter. Front ferrule shoulder: Front ferrule shoulder prevents body expansion and nut jamming, caused by over-tightening.	Provides maximum user safety under high pressure/vibration conditions. Prevents overstressing, which causes tubing failure and possible injury. System efficiency is improved by maximizing flow. Provides unmatched remake life. Maximizes value and economy.
<b>2. BUTT SEAL</b>	Provides a secondary seal and eliminates dead space.	Maximizes fitting leak integrity and user safety. Can seal with scratched tubing. Increases accuracy in sampling applications. Reduces pump-down time in vacuum applications.
<b>3. HOKE VALVES WITH INTEGRAL HOKE GYROLOK END FITTINGS</b>	Controlled ferrule drive prevents end connection expansion, thus prolonging valve life and eliminating the need to use female-ended valves with separate fittings. Eliminates a possible leak path and extends valve life.	Long product life and maximum value. Safety and economy.
<b>4. GYROLOK SAFETY CHANGER NUT AND FERRULE SETS</b>	Nut and ferrule sets supplied on rods, already correctly oriented. (Not necessary to handle ferrules when replacing components.)	Safest, simplest device for component replacement.
<b>5. GYROGAGE</b>	Marks tubing to show that tubing has been properly inserted into fitting, and that fitting has been properly tightened.	Maximum safety resulting from ability to verify correct tube insertion and proper tightening.
<b>6. SIZING ANGLE</b>	Slight taper in the base of the tube socket reduces possibility of tube sticking	Less tube sticking during disassembly saves time and money
<b>7. SILVER-PLATED NUT THREADS</b>	Silver-plating extends fitting life by preventing galling, up to 1200° F.	Extended product life at extreme temperatures.
<b>8. MATERIAL TRACEABILITY ON FITTING BODY AND NUT</b>	Bodies and nuts made of 316 Stainless Steel and Monel are heat code traceable to Certified Material Test Reports.	Traceability provides added safety. Certified Material Test Reports are available for review and verification.
<b>9. PFA FERRULE COATING</b>	Front ferrules—Sizes larger than 1" (25mm) are PFA coated.	Increased resistance to media and atmospheric corrosion.

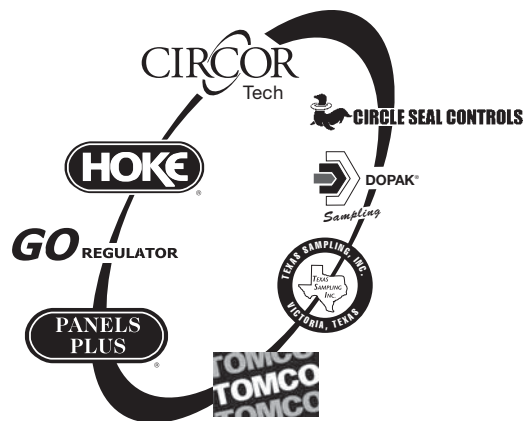

**Hoke • GO Regulator • Tomco • CIRCOR Tech**

405 Centura Court • PO Box 4866 (29305)

Spartanburg, SC 29303

Tel (864) 574-7966 • Fax (864) 587-5608

[www.circortechnologies.com](http://www.circortechnologies.com)

**Hoke Controls / Panels Plus**

2054 Francis St.

Ontario, CA 91761

Tel (909) 923-3770

Fax (909) 923-2550

[www.circor-panelsplus.com](http://www.circor-panelsplus.com)

**Dopak Inc.**

9572 Kempwood

Houston, Texas 77080

Tel (713) 460-8311

Fax (713) 460-8578

[www.dopak.com](http://www.dopak.com)

**Texas Sampling, Inc**

3706 Rio Grande

Victoria, Texas 77901

Tel (361) 575-8087

Fax (361) 575-8157

[www.texassampling.com](http://www.texassampling.com)

**Circle Seal Controls**

2301 Wardlow Circle

Corona, CA 92880

Tel (951) 270-6200

Fax (951) 270-6201

[www.circlesealcontrols.com](http://www.circlesealcontrols.com)

**CIRCOR Instrumentation**

**Technologies**

**Central Europe**

Leeuwenhoekweg 24

2661 CZ Bergschenhoek

The Netherlands

Tel +31 10 4206011 • Fax +31 10 4566774

[www.circortechnologies.com](http://www.circortechnologies.com)

**Hoke GmbH**

Weitzesweg 11

Postfach 1541

D-61118 Bad Vilbel-Dortelweil

Germany

Tel +49 6101 82 56 0

Fax +49 6101 82 56 40

[www.hoke.de](http://www.hoke.de)

**CIRCOR Instrumentation Technologies**

CIRCOR Instrumentation Technologies (CIT) is a product group of CIRCOR International (NYSE: CIR), specializing in fluid process control solutions with orifice sizes typically up to 1". Our main product lines include ball, needle, packless, diaphragm, solenoid, and metering valves, pressure regulators, quick couplers, Gyrolok® compression tube fittings, and fully integrated sampling systems.

CIT markets primarily to the petrochemical, refining, power generation, food and beverage, semiconductor, and pharmaceutical industries, and to OEM's. CIT separates itself from the competition by offering highly engineered components manufactured to exacting standards and a variety of custom options.